

ASSEMBLY INSTRUCTIONS
Trevi 209 OVAL POOLS

Dear Customer

Congratulations! You have purchased a pool of superior quality and durability. To achieve the best possible results, follow the instructions carefully. Failure to follow the installation procedures may result in damage to your pool or property and void your warranty. We recommend that you make a preliminary study of the instructions booklet to familiarize yourself with the different parts of your pool. Make sure that you understand each step thoroughly before you begin assembling.

We wish you a most pleasant and refreshing summer.

WARNING: Be sure you have read and understood the "Safety Information" sheets before you begin your pool installation.



WARNING: For your safety, your pool is not designed for diving and/or jumping head first. Please do not dive. Diving may result in permanent injury or death.

1 SITE PREPARATION

When selecting the site for your pool, take into account city by-laws regarding fences and utilities laws pertaining to electrical cables, as well as the landscaping which you are planning once the pool is installed.

Drive a stake into the ground at points A and B respecting the distance of the straight section between those two points. Draw two half circles 15 cm to 20 cm (6" to 8") longer in radius than the pool. Join the two half circles adding 88 cm (36") on each side to leave room for the stays. Remove all grass from the area which you have just outlined.

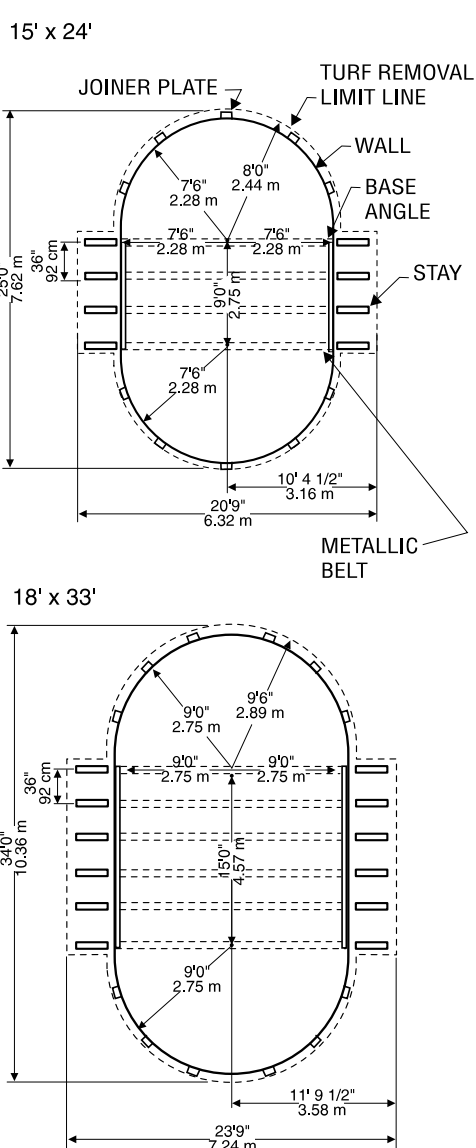
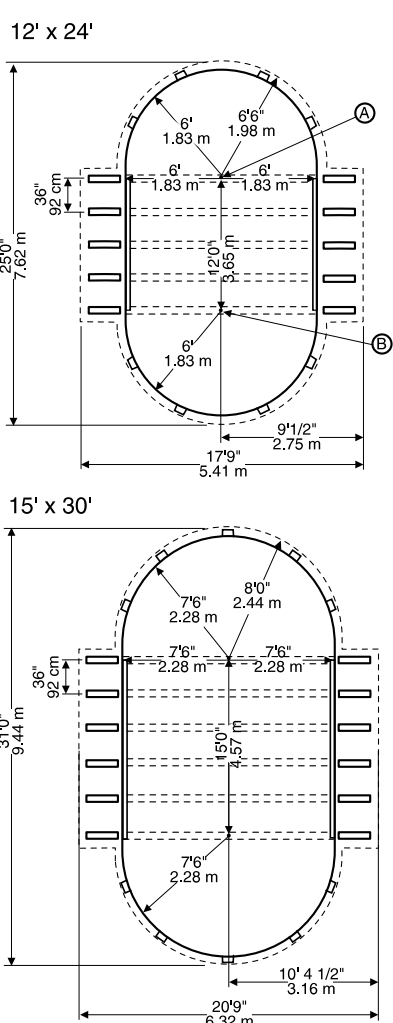

Chart

POOL DIAMETER	SAND	STONE DUST*
3.66 m x 7.32 m (12' x 24')	2 Tons	1 Ton
4.57 m x 7.32 m (15' x 24')	2 1/4 Tons	1 1/4 Ton
4.57 m x 9.15 m (15' x 30')	2 1/2 Tons	1 1/2 Ton
5.49 m x 10.05 m (18' x 33')	3 Tons	2 Tons

* If you only use sand, add stone dust tonnage to sand.

2 SITE LEVELLING

Type A Assembly
SITE LEVELLING FOR OVAL POOLS WITH BELTS

For an oval pool with belts, the bottom must absolutely be levelled, using a carpenter's level and a straight plank. Eliminate any protrusions. Ensure that the surface is free of debris such as rocks, wood, etc.

For future angle plates, dig 6" deep by approximately 5" wide trenches. For the belts section, do not dig trenches any deeper than 7,5 cm (3") - (see Illustration A)

Type B Assembly
SITE LEVELLING FOR OVAL POOLS WITH CONCRETE SIDE WALK

An oval pool with a concrete walk is more advantageous because it gives a more slanted slope to the bottom of the pool. 15 cm (6") should be the maximum height.

For future angle plates, you must dig 6" deep trenches (see Illustration B)

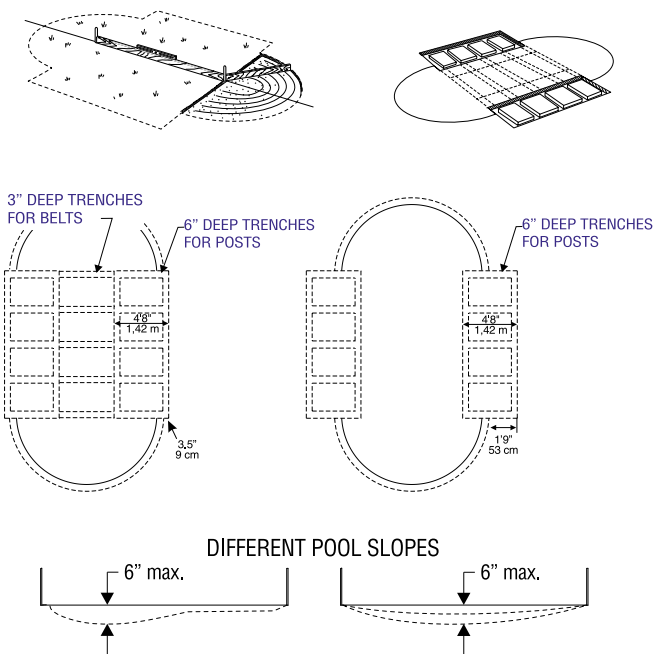

3 BOTTOM DRAIN ASSEMBLY (if applicable)

Dig a hole 30 cm (12") wide by approximately 25 cm (10") deep in the center of the circumference.

From the center hole to the projected location of the pool motor, dig a 15 cm (6") wide trench. Place the removed soil aside to be used later to cover the hose.

Bottom Drain Assembly

Place teflon around the threaded plug. Screw in drain holes using large pliers. Glue the connector in the appropriate opening. Glue connector in the appropriate opening.

Take one of the two rubber rings and adjust it to the top of the drain, aligning the holes carefully. Secure with strips of adhesive tape to prevent sand from penetrating inside the holes once the drain has been installed.

Secure one end of the long black or white hose inside the drain spout. First apply glue on the drain spout and inside the drain end, then secure with one or two collars.

Cut the hose so that it ends with the stone dust (or sand). Measure the pool radius from the center of the drain, then add 15 cm (6").

Place the assembled bottom drain in the hole so that it is approximately 1.3cm (1/2") higher than the surface soil. Bury the hose, levelling the drain as much as possible. Compact the soil, using your feet and a tampering tool as well.

Mix three (3) shovels of stone or sand dust with one half shovel of pure cement, adding a small quantity of water, then pour the cement around the drain until it reaches 1.3 cm (1/2") from the top.

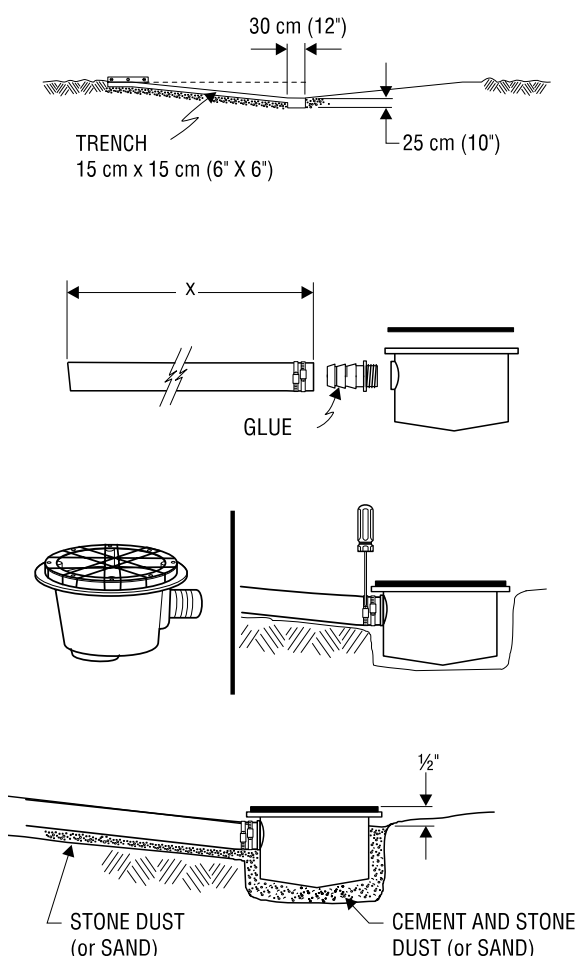

4

BASE ANGLE ASSEMBLY

To assemble, it is important to secure the support post to the rail, using one 3/8 X 2 3/4" bolt and then the base angles to each other using the support post (with 3/8 X 2 3/4" (70mm) bolt). The last operation of this procedure is the assembly of the track fasteners at each end of the pool centre.

Secure the groove of the joiner plate to the base of the vertical post using a pool standard screw. Finally, secure angle plates to "J" post plates on each side of the support post using standard bolts.

NOTE : Illustration 4 demonstrates the installation of an inside or belts platform. If you are planning a concrete walk installation, you must secure the support post in the second series of holes, which you will find in the middle of the horizontal post. (Illustration 4, position B)

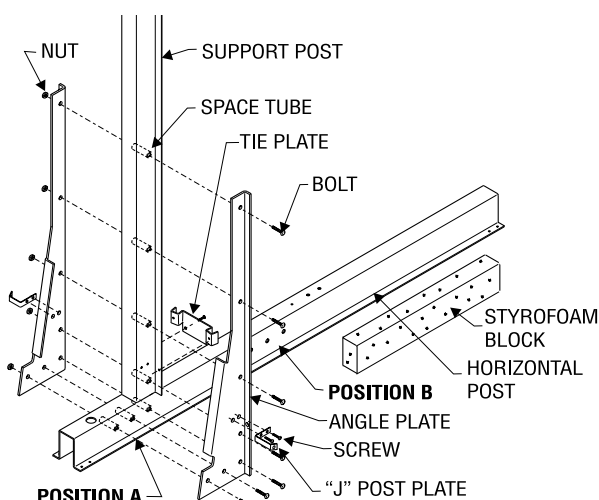

5

BELT INSTALLATION (if applicable) - Type A Assembly

Type A Assembly Only

Study illustrations and chart carefully. You are now ready to assemble the metallic belts. Refer to indications on the chart for the exact number of metallic belts and sections per belt according to their respective length.

Install nuts and bolts 1/4-20 x 3/4" (19mm) properly, as indicated in Illustration 5.2, making sure the bolt head is on top.

These lengths must link with the rails on both sides (Illustration 5.3), using the 1/4-20 X 3/4" (19mm) bolts and nuts.

Illustration 5.3

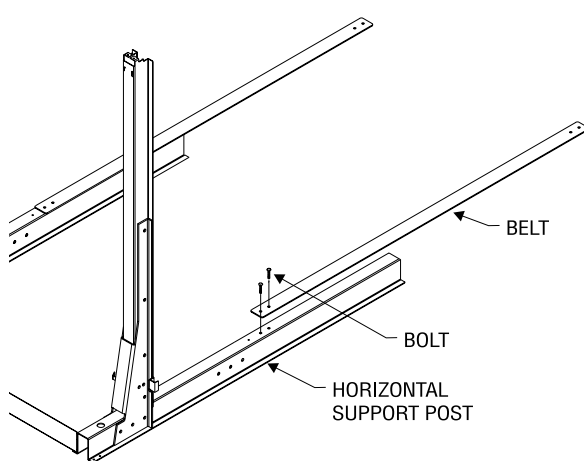
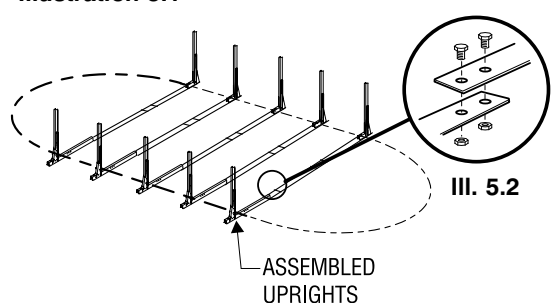

Illustration 5.1



Chart

ILLUSTRATION	POOL DIMENSIONS		NO. OF METALLIC BELTS	NO. OF SECTIONS PER BELT	
	FEET	METERS		54,5" LENGTH	38,875" LENGTH
4.1	12 X 24	3.66 X 7.32	5	15 (3 per belt)	-
4.1	15 X 24	4.57 X 7.32	4	12 (3 per belt)	4 (1 per belt)
4.1	15 X 30	4.57 X 9.15	6	18 (3 per belt)	6 (1 per belt)
4.1	18 X 33	5.49 X 10.05	6	18 (3 per belt)	12 (2 per belt)

6

ANGLE PLATES ASSEMBLY

Number of uprights and stays for the straight section:

- 10 for a pool of 3.66 m x 7.32 m (12' x 24')
- 8 for a pool of 4.57 m x 7.32 m (15' x 24')
- 12 for a pool of 4.57 m x 9.15 m (15' x 30')
- 12 for a pool of 5.49 m x 10.05 m (18' x 33')

Place the assembled uprights from Step 4 (or 5 if you are using belts) in trenches already dug.

The angle plates are placed between each assembled upright using two standard screws on each end of the horizontal post, as per Step 4 (See Illustration 6).

Once the angle plates are installed, place the sheet on the horizontal post using six standard screws (See Illustration 6).

Illustration 6

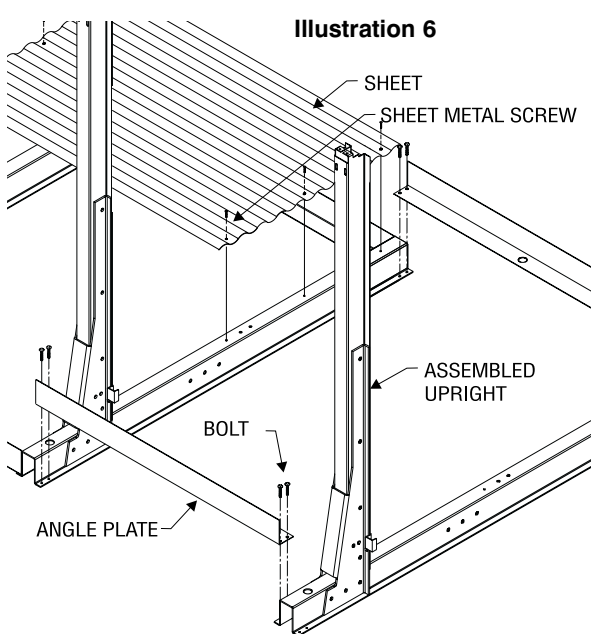

7

BOTTOM TRACK ASSEMBLY

First, identify grooves A and B, which you will find at the end of the straight sections (Illustration 7.3). Depending on the size of the pool, refer to the chart for the exact number of grooves in the straight section.

Straight Section: Secure the straight section grooves on the tie plates provided using standard screws (Illustration 7.1).

NOTE: The straight section grooves have a curved radius and the grooves are close to the extremities.

Sections A & B: Slip the end of the groove (close to the extremities) on the tie plate of the last track of the straight section and screw together. On the other end, set in place the first plate of the round section.

Half-Circle Section: Using the round stabilizer and the joiner plate, start with the first plate of the round section. Repeat this procedure until the half circle is completed. (Illustration 7.2).

NOTE: Make sure to leave approximately 13 cm (1/2") gap between each end of the track to allow easy adjustment when installing the steel wall and inserting the upright.

Before going to step 8, make sure that the centre of the pool is properly squared and metallic belts stretched (see Illustration 7.2).

Making sure the line is squared, secure the installation with large nails (Illustration 7.1).

Chart

POOL DIAMETER	ROUND SECTION TRACK	NUMBER OF TRACK A-B	STRAIGHT SECTION TRACK	NUMBER OF PLATE
12' x 24' (3,66 m x 7,32 m)	6	4	8	8
15' x 24' (4,57 m x 7,32 m)	8	4	6	10
15' x 30' (4,57 m x 9,15 m)	8	4	10	10
18' x 33' (5,49 m x 10,05 m)	10	4	10	12

Illustration 7.2

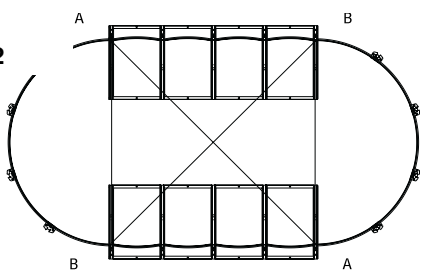

Illustration 7.1

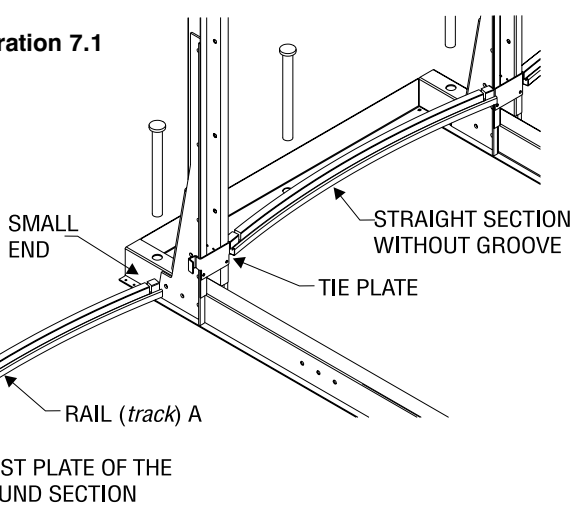
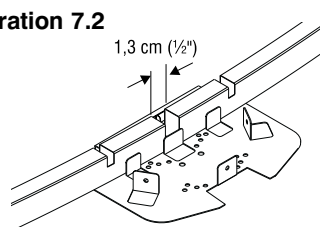

Illustration 7.2



8

WALL INSTALLATION

Choose the filter location (always beside a half circle, never a straight section).

The starting point will be at that location so that the skimmer and return holes are as close as possible to the filtration system. Before uncoiling the pump, make sure the pre-punched holes for the skimmer and pump are at the top and facing the planned location of your filter.

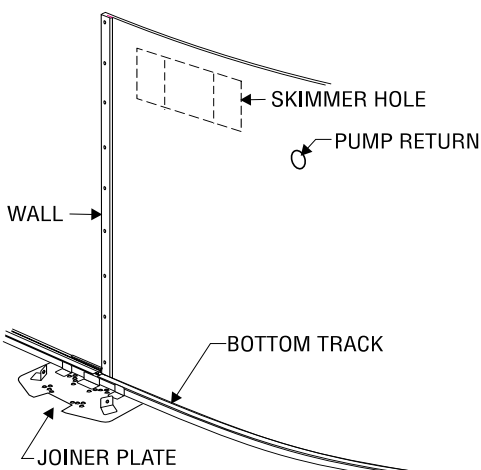
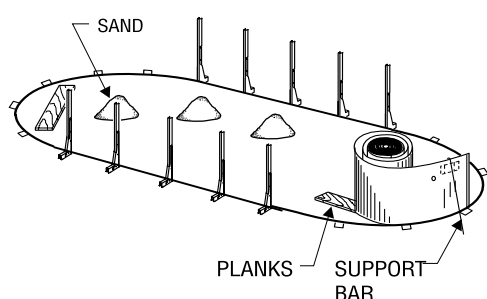

8

WALL INSTALLATION (continued)

Begin inserting the wall into the bottom wall tracks in the middle of a joiner plate. At first, the wall is kept in place with one or two support bars (or extra persons). One person uncoils the wall on a beam or a plank, while a second person inserts it in the bottom wall tracks. Do not uncoil more than 3 m (10') of wall before you install a support bar to reinforce the structure.

Once the wall is completely uncoiled, you may find that it is too long or that both ends do not meet by a few centimetres. If such is the case, you must gently push the wall in or out. If this does not work, roll up the wall again, realign the grooves and uncoil the wall again. If the spread is too wide, measure the wall and check it against the following chart.

Illustration 8.1

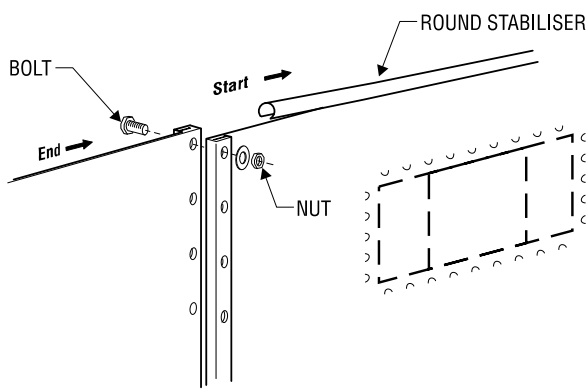

Chart

POOL DIMENSIONS	ACTUAL LENGTH OF WALL
3.66 m X 7.32 m (12' X 24')	18,83 m (61' 9 3/8")
4.57 m X 7.32 m (15' X 24')	19,88 m (65' 2 1/2")
4.57 m X 9.15 m (15' X 30')	23,53 m (77' 2 1/2")
5.49 m X 10.05 m (18' X 33')	26,40 m (86' 7 9/16")

When you prepare to join the ends of the wall, make sure the end that is reinforced by the fold is inside the circle, facing the liner and that the other end faces outward (Illustration 8.1).

When the wall joint is secured, install the round stabilisers on top of it.

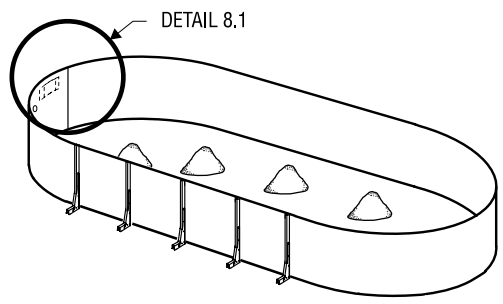

IMPORTANT: Due to the enormous pressure exerted by the water on the steel wall, it is absolutely essential that all the bolts are screwed in tightly and no hole is left open. All bolt heads must be inside with washer and nut outside. Cover all bolt heads with heavy fabric tape.

9

SAND BASE FINISHING

You can now spread approximately 10 cm (4") of compacting sand all around the inside base of the wall in order to protect the liner from the cutting edges of the bottom wall tracks and the stone dust (if applicable). Or install a prefabricated cove, if available.

SAND BASE FINISHING

Level finishing sand one last time. Make sure that any sharp stones, debris or roots have been removed from the surface. For better protection, spray sand with water and pack it once more until the base is nicely even.

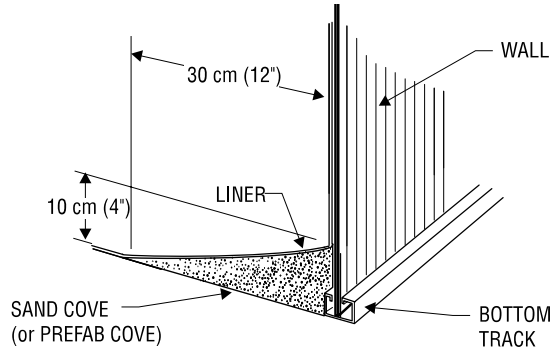

10

VINYL LINER INSTALLATION

Before pulling the liner up against the wall, insert a vacuum cleaner hose down into the pump return hole to approximately 15 cm (6") from the ground.

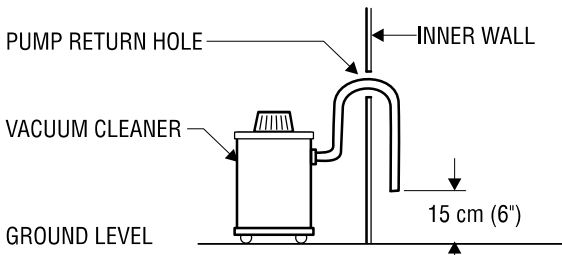

Maintain the hose in place with adhesive tape. Don't forget to block the skimmer hole with adhesive tape to prevent air from leaking in.

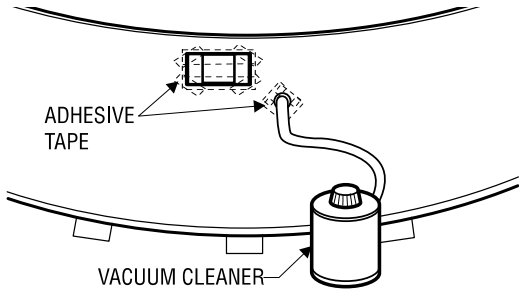

Place the unfolded liner in the center of the pool area at right angles with the skimmer hole. Make sure you wear light, flat-soled shoes to walk on the sand as the slightest heel mark could

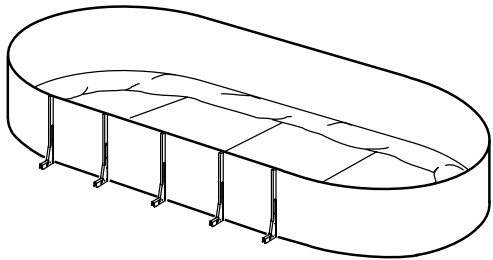

be visible once the pool is filled. Carefully unfold the liner, bringing the bottom-sidewall seam close to the wall base. Make sure that the side with the protruding seams faces downward or that the patterned side faces upward. Install the round stabiliser on the wall. Lift up a section of the liner over the top of the wall leaving a 10 cm to 15 cm (4" to 6") fringe outside the wall. Secure the liner with a plastic coupler then install the joiner plates on top of each upright.

At this point, the liner may be too tight, making it difficult to drape the overlap or, on the contrary, too loose. In such cases, you will have to redistribute the tension in the liner by removing some of the couplers and readjusting the liner.

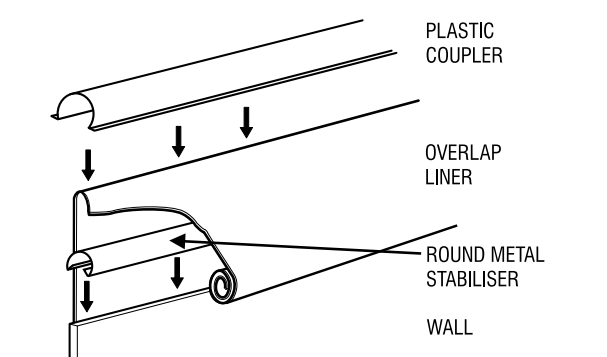

Installation detail of the u-bead liner.

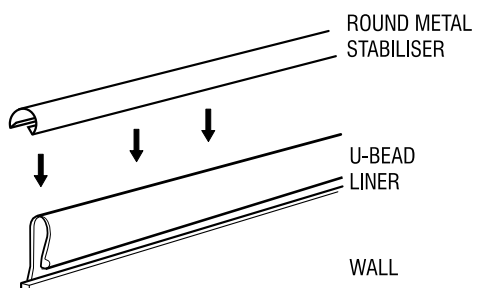

Hang the liner on the top of the wall and install the round stabiliser to secure.

Start the vacuum cleaner to allow the liner to adhere to the wall and check for excess tension at the bottom or for wrinkles. Adjust the liner by removing couplers if needed, to lift or lower it in order to ensure a perfect fit.

Fill the pool up to the base of the wall before stopping and removing the vacuum cleaner.

PUMP RETURN FITTING

After you remove the vacuum cleaner, you may install the return fitting. Place the return fitting ring against the liner and adjust it so that it is perfectly aligned with the hole in the wall.

When the ring is properly positioned and secured, cut the liner in the middle of the ring. Insert the return fitting from the inside, placing the first gasket between the return fitting and the liner and the second between the wall and the liner. Then tighten the outside ring with large pliers, taking care not to create the liner.

BOTTOM DRAIN (optional)

Find the holes through the middle of the liner and screw the ring and gasket in against the liner before cutting the liner in the middle of the ring, then screw on the drain cover.

11

VERTICAL UPRIGHT INSTALLATION

MODÈLE TREVI 209

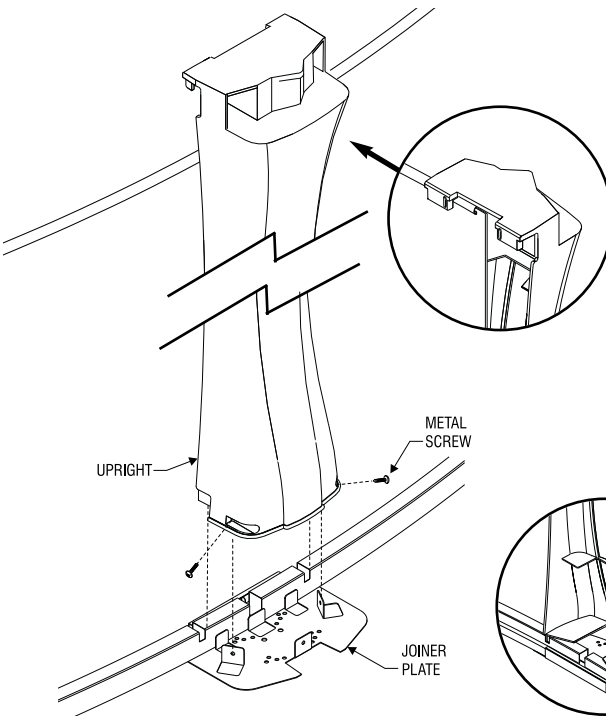

Attach the uprights to the bottom joiner plates with two or three metal screws. You will find them in the hardware bag depending of the model.

Uprights must be installed outside the flanged part of the joiner plate and in the two notch of the wall track.

Note: For Model Trevi 215, top and bottom joiner plates are the same.

TREVI 215 MODEL

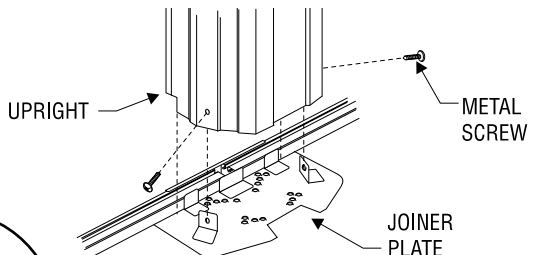

12 VERTICAL UPRIGHT INSTALLATION (continued)

For Model Trevi 209, position the joiner plate on the upper side of the upright, and secure with two (2) metal screw.

TREVI 209 MODEL

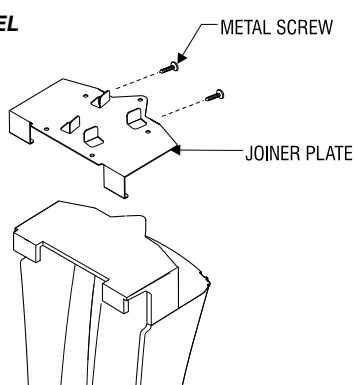

TREVI 215 MODEL ROUND SECTION

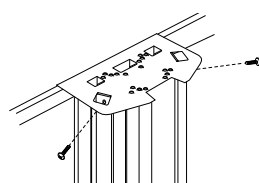

STRAIGHT SECTION

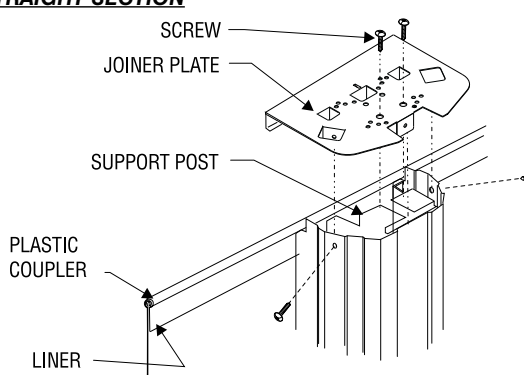

13 TOP SEAT INSTALLATION

Place the top seat on the upper side of the upright, and secure with two (2) metal screw. The screw in the interior pool side must be protected on the bit with the screw guard.

TREVI 209 MODEL

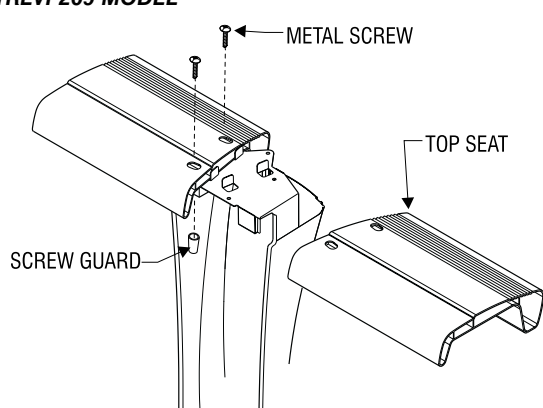

For Model Trevi 215, align the top seat with the joiner plate. Secure the seat with four (4) metal screws.

TREVI 215 MODEL

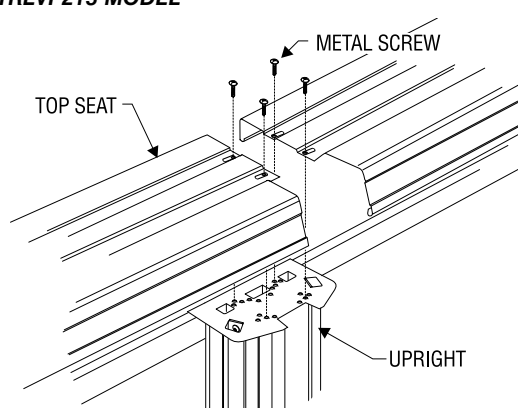

14 SEAT CAP INSTALLATION

For Model Trevi 209, put the seat cap on the inside section of the seat and interlock with the upright, and secure with one (1) metal screw. Place the screw cap on the top.

Trevi 209 MODEL

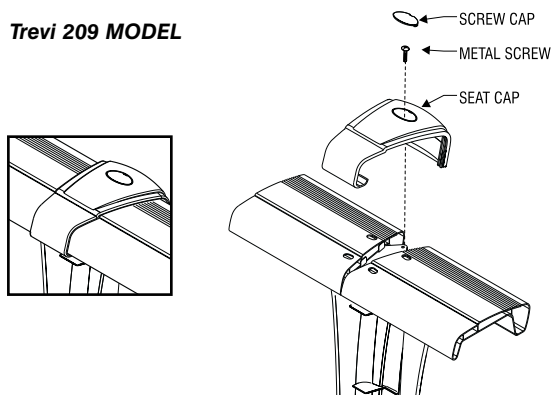

For Model Trevi 215, put the seat cap on the inside section of the seat and secure to the upright with two (2) metal screws. Secure the other seat cap section with two (2) other metal screws.

Trevi 215 MODEL

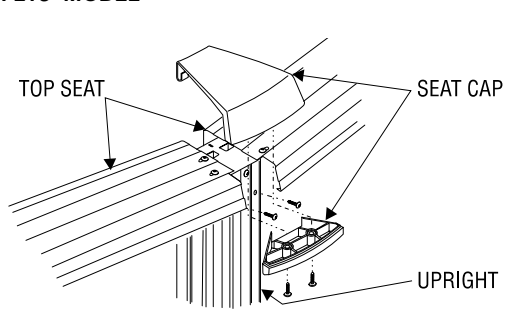

15 CONCRETE WALK INSTALLATION (without belt)

Type B Assembly Only

Prepare a wood frame long enough to frame all angled posts, 91.5 cm (3') wide and a maximum height of 15 cm (6") since the cement must not touch the wall directly but the base support only.

Drive iron stakes about 46 cm (18") apart into the ground not to exceed 7.6 cm (3") from ground level, to prevent the future walk from receding with the water pressure.

Secure the frame using iron stakes.

Introduce the first cement coat (approx. 7.6 cm (3")), then place the iron grid to even out the cemented surface from side to side in order to prevent it from cracking in years to come.

Introduce the last cement coat so that it comes up to the top of the base supports by creating a descending slope toward the end of the frame (for rainwater drainage). Smooth out using the rounded trowel.

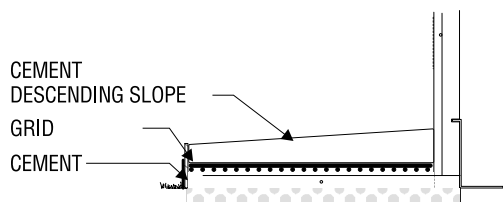

Use the corner trowel to finish along the wooden frame edge.

After 24 hours of drying, you may fill with water and remove the wooden frame.

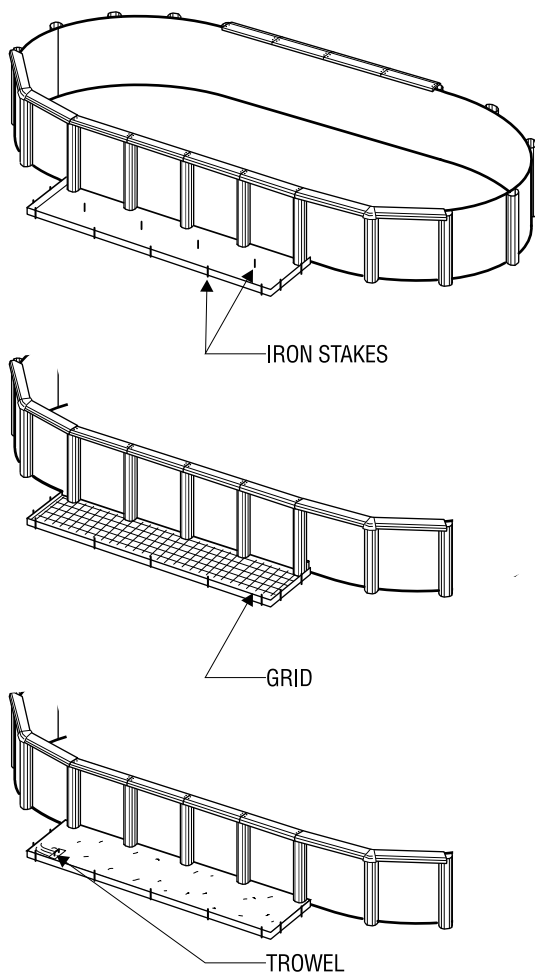

16 SECURITY SIGNS INSTALLATION

Position the Safety procedures panel on the outside of the pool. This panel must be at the most visible place from the yard on your pool.

Place the four (4) safety stickers inside the pool in a way that it's seen from any entry point of the swimmer (See positioning drawing).

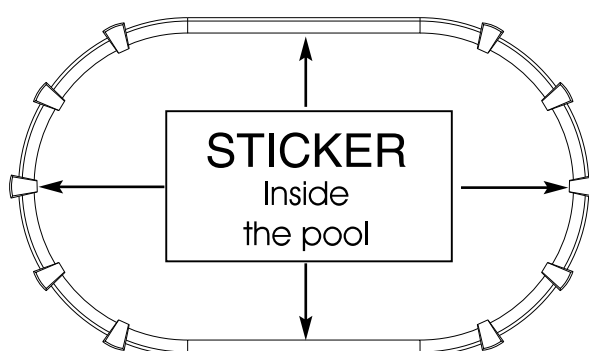
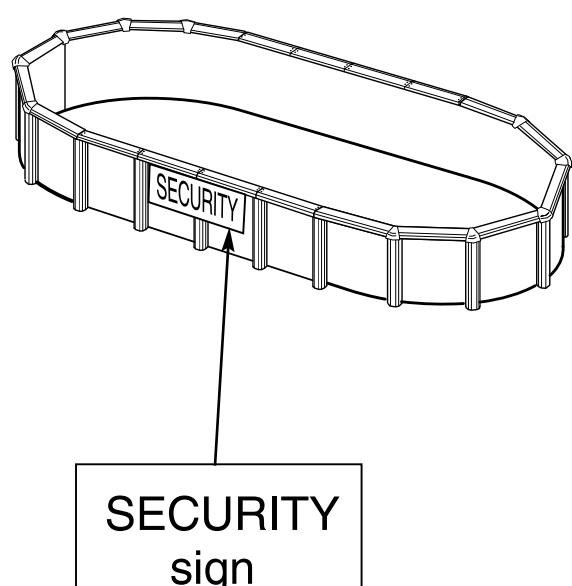

17

FILTRATION SYSTEM ASSEMBLY

Note: See 'Safety Information' Manual, Page 1.

As described in the manual, all components of the filtration system should be placed to prevent a child to climb on top and get access to the pool.

Using a little bit of stone dust (or sand), place at level a patio stone 61 cm x 76 cm (24" x 30") before installing the motor and filter

Position the motor on the stone and insert the two nozzles to connect the hoses.

Then, install the filter tank. Adjust the lateral assembly properly in its channel.

It is sometimes necessary to install the laterals.

Patch the center hole of the lateral assembly using the plug to allow filtering sand to flow into the tank.

Remove the plug. Install the joint in the cavity and secure the filter head by placing the back wash position on opposite side of the pool.

Install necessary nozzles, then connect hoses using collars.

1. The first hose runs from the top of the pump to the side of the filter head;
2. The second one goes from the pump to the skimmer (or to the bottom drain valve);
3. The third goes from the front of the filter head to the water return or from the front of the chlorinator to the water return.

A back wash hose may be placed behind the filter head.

If there is a chlorinator and/or heat pump, they must be assembled at the filter exit.

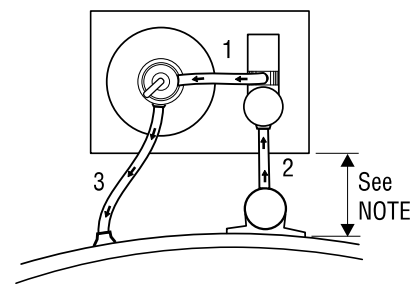
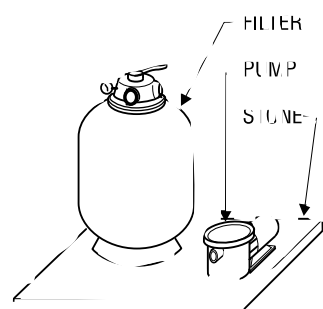
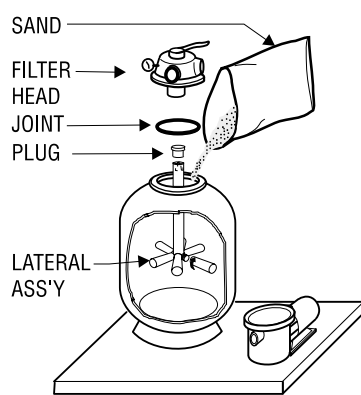

18

DRAIN VALVE ASSEMBLY (if applicable)

Insert threaded nozzles, if applicable, in order to be able to screw the valve in the skimmer.

Connect the drain hose to the bottom nozzle. Connect the motor hose to the side nozzle.

The threads on all threaded nozzles must be covered with teflon tape prior to installing in order to prevent water leaks. Teflon is applied to the threads as follows: little or none on the first few threads (to facilitate introduction) and several layers toward the end threads (for better watertightness).

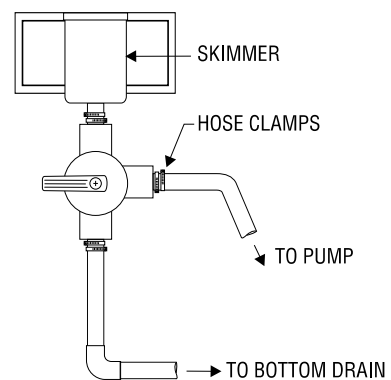

19

PARTS LIST

ARTICLE	DESCRIPTION	12' x 24' 18,23 m	15' x 24' 19,87 m	15' x 30' 23,53 m	18' x 33' 26,41 m
A	Top seat	10	12	12	14
B	Top seat straight section	8	6	10	10
C	Upright	8	10	10	12
D	Seat cap (Trevi 209)	18	18	22	24
DD	Screw cap	18	18	22	24
E	Joiner plate	26 (8)	28 (10)	32 (10)	36 (12)
F	Round stabiliser	10	12	12	14
G	Plastic coupler	18	18	22	24
H	Bottom track	18	18	22	24
I	Reinforcement plate	8	10	10	12
J	Metallic belt 54.5" (1,38 m)	15	12	18	18
K	Metallic belt 38.875" (0,97 m)	-	4	6	12
L	Angle plate	20	16	24	24
M	Horizontal post	10	8	12	12
N	Support post	10	8	12	12
O	Tie plate	10	8	12	12
P	Bolt 1/4-20 X 3/4"	60	56	84	96
Q	Bolt 1/4-20 X 3/4"	70	56	84	84
R	Nut 1/4-20	110	96	144	156
S	Angle plate	16	12	20	20
T	"J" Post plate	20	16	24	24
U	Sheet	8	6	10	10
V	Vinyl liner	1	1	1	1
W	Wall	61' 9 3/8" (18,83 m)	65' 2 1/2" (19,87 m)	77' 2 1/2" (23,53 m)	86' 7 9/16" (26,41 m)
X	Vis Trevi 215 (Trevi 209)	370 (226)	336 (192)	452 (276)	476 (284)
XX	Screw guard (Trevi 209)	36	36	44	48
Y	Bolt & nut (for 52" (1,32 m)) for wall	25 (29)	25 (29)	25 (29)	25 (29)
Z	Drain kit (if applicable)	1	1	1	1

