

# PRESTO™ STAINLESS STEEL POOL COVER REEL FOR IN-GROUND POOLS

**1**

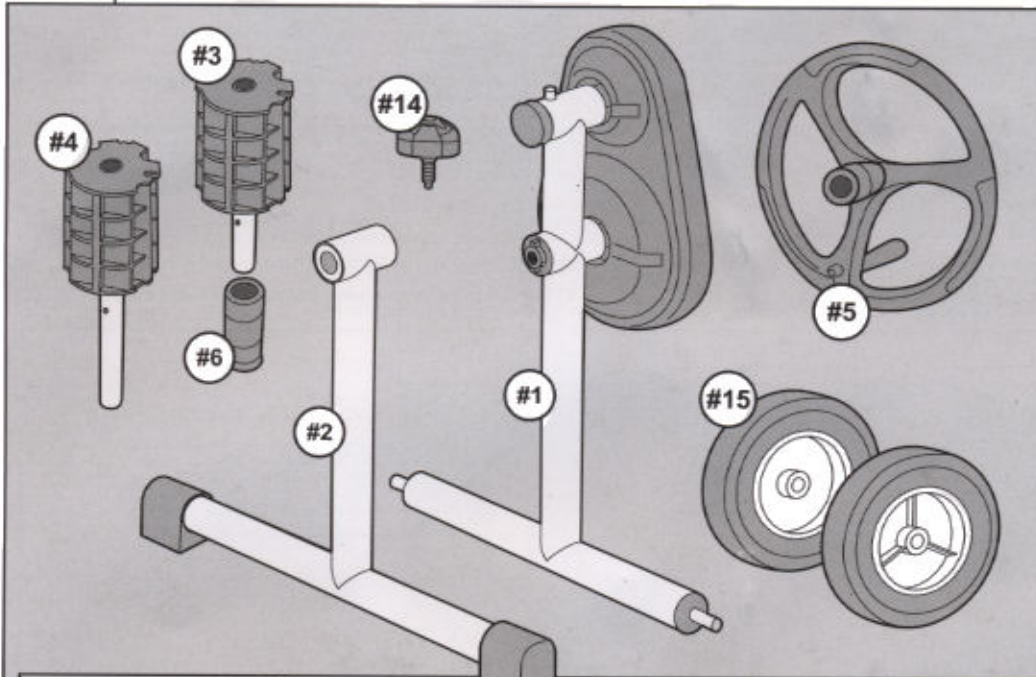

GB	Ref.	Description	Qty.
	#1	Frame with Gear Box	1
	#2	Frame	1
	#3	Short hub	1
	#4	Long hub	1
	#5	Crank Wheel (with handle)	1
	#6	Grip	1
	#7	Nut and screw	3
	#8	Self tapping screw	4
	#9	Washer	1
	#10	Screw	6
	#11	Cover strap	8
	#12	Cover clip	8
	#13	Buckle	8
	#14	Threaded knob	1
	#15	Wheels	2
	#16	Wheel Retaining ring	2

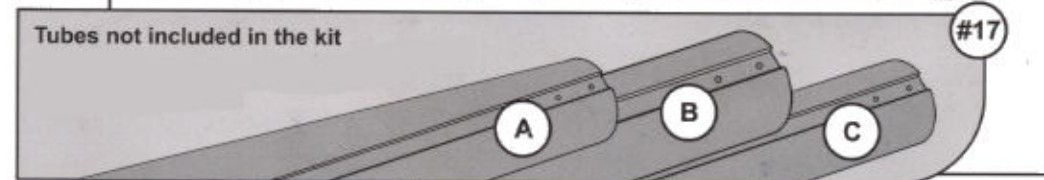

**2**

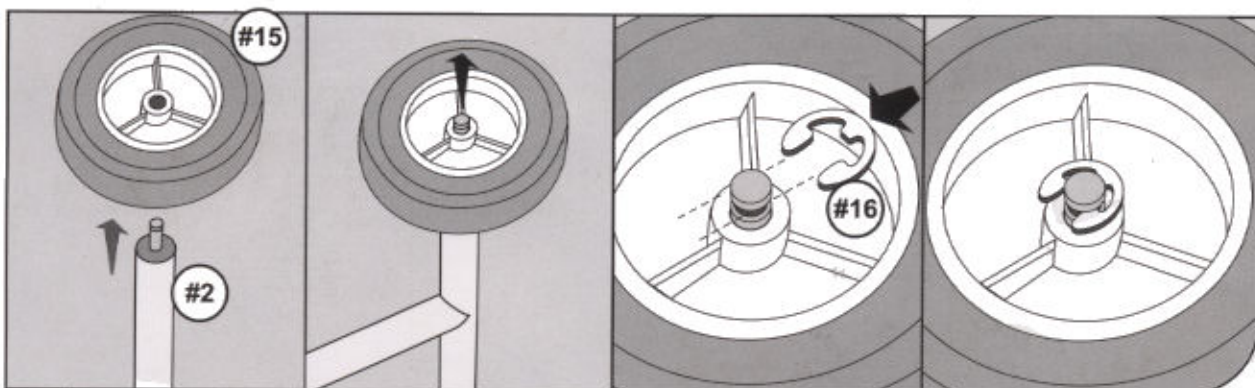

- GB
- Slide the wheel #15 onto the axis of the frame #1.
  - Put the retaining ring #16 over the wheel and align the hook end of retaining ring to the groove around the axis.
  - Use a screwdriver to push the retaining ring completely down into the groove of the axis.
  - Make sure the retaining ring is in place and the wheel is totally secured under the retaining ring before the next step.

3

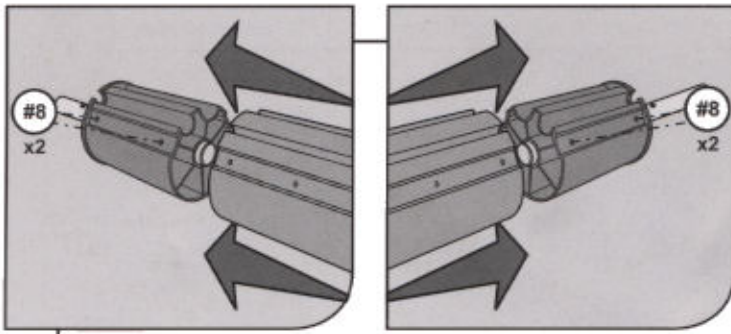

GB **NOTE:** Tube set comes with 3 sections like #17. Two sections have same diameter (marked "A" & "C") and one section has a bigger diameter (marked "B"), which is to be placed in middle to connect sections "A" & "C" on each side.

- Align the groove on the hub with pre-drilled holes on tube "A", and insert the short hub #3 into one end of tube "A". Secure the assembly with two self tapping screws #8.
- Repeat the operation with the long hub #4 into one end of tube "C" and secure the assembly with two self tapping screws #8.

4

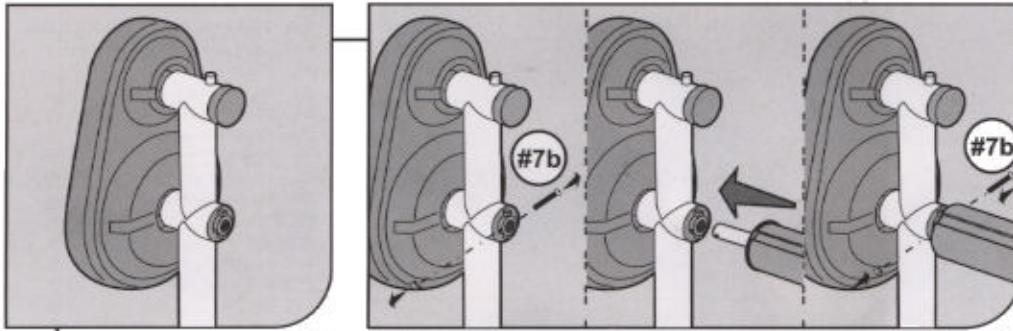

GB • Unfasten and take out the screw #7b from the plastic sleeve on the lower short tube of gear box, and then insert the axle of short hub #3 into the short tube until its hole matches the hole of the plastic sleeve and the short tube. Put the screw #7b through the hole and secure with the nut.

5

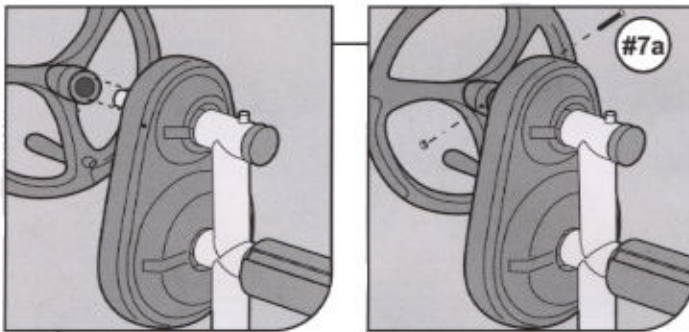

GB • Slide the Crank Wheel #5 onto the top short tube of the gear box until its hole matches the hole on the short tube. Put the longer screw #7a through the hole and secure with the nut.

6

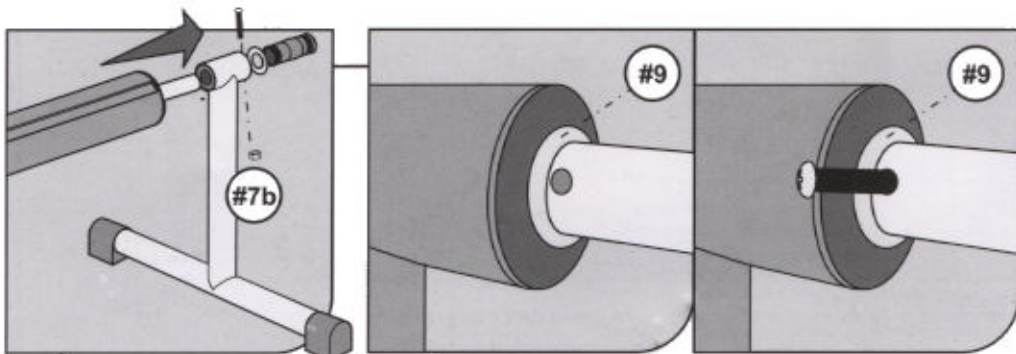

GB • Assemble the axle of long tube hub #4 onto the frame #2, place the washer #9 behind the frame. Put the shorter screw (of #7b) through the hole on hub axle and secure with the nut. Slide the grip #6 onto the hub axle.

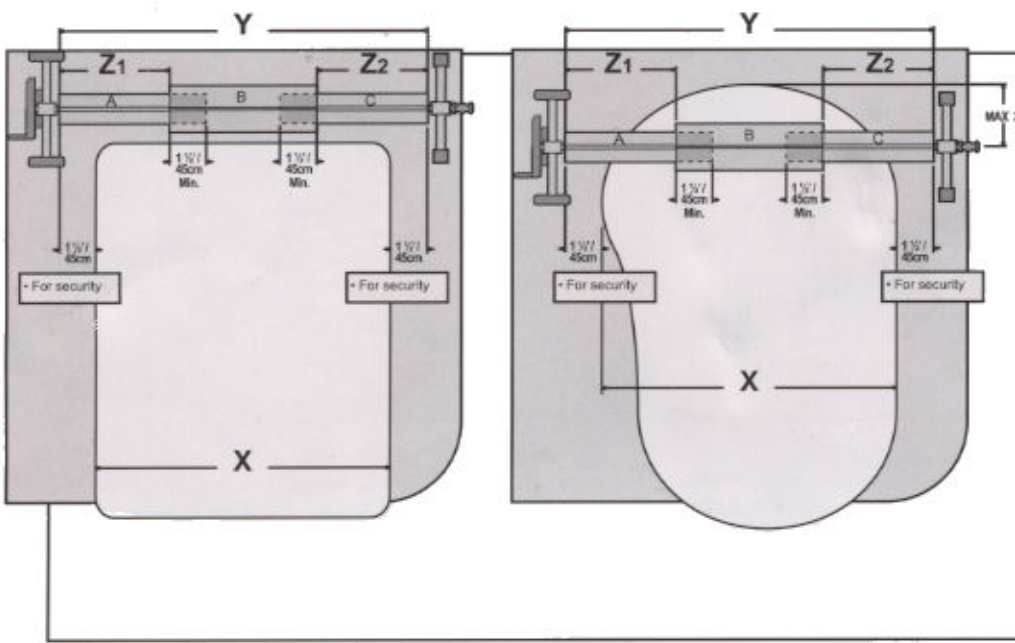

**7**

- GB
- Measure the maximum width of your pool (between the pool inner edge) = X.
  - Insert the tube "A" and "C" into the tube "B", and slide them until you have the required size + 1 1/2" (45cm) margin on right and left side of X as shown in above diagram.
  - Ensure that the tube "B" is exactly centered so that Z1 and Z2 are equal.
  - Also ensure that there is a minimum tube overlap of 1 1/2" (45cm) on both sides of the tube "B".

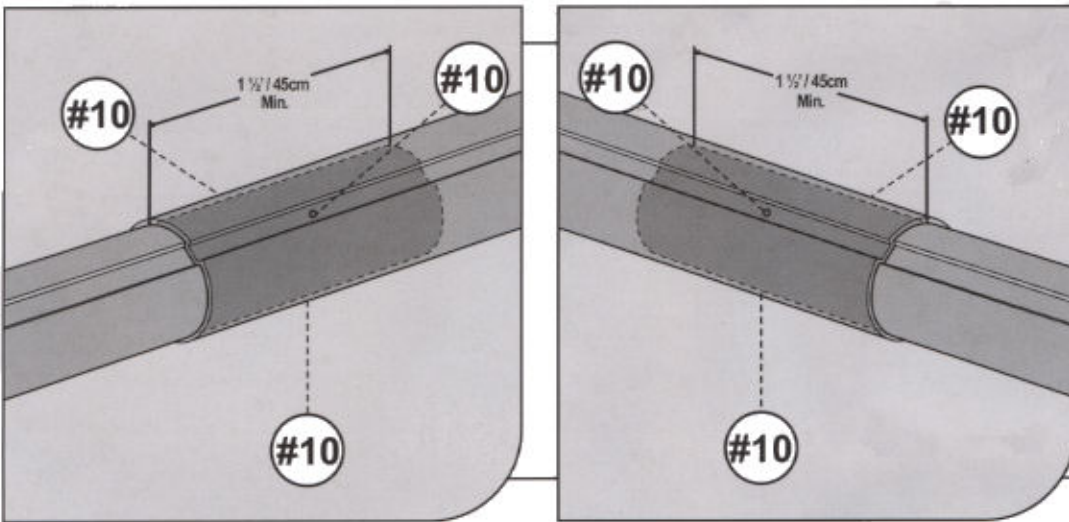

**8**

- GB
- Align the pre-drilled holes on tubes "A" and "C" respectively and then fix the tube connection by fastening 3 screws #10 into the pre-drilled holes.

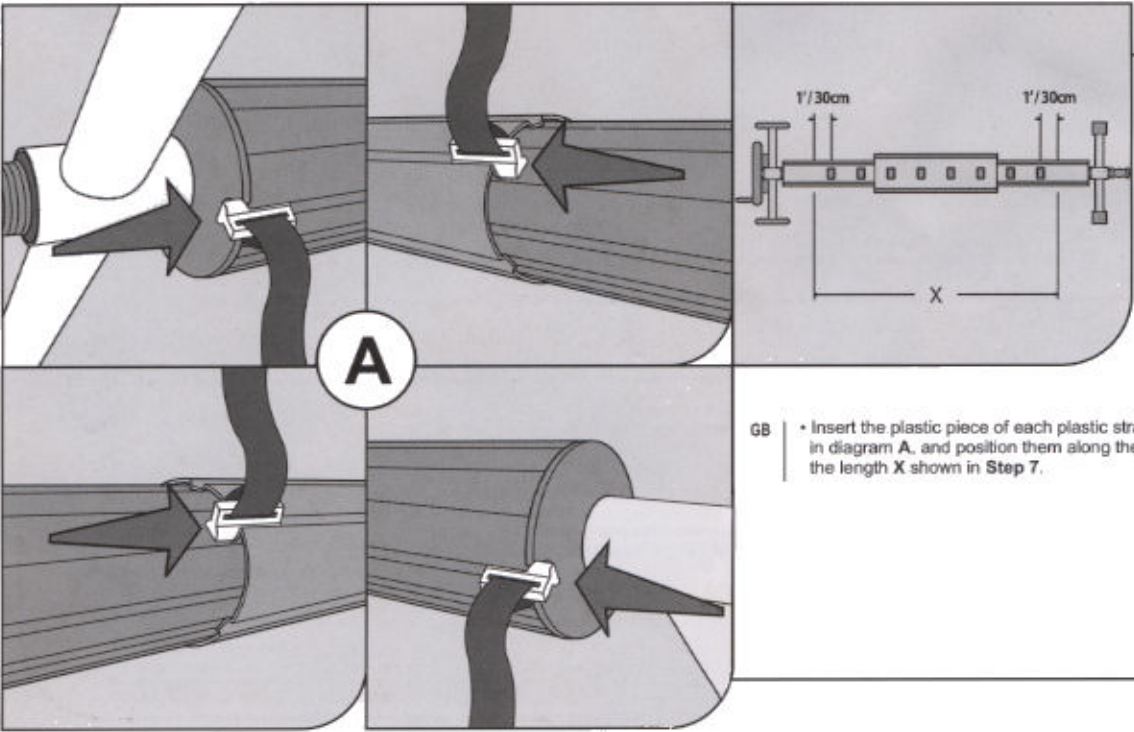

**9**

- GB
- Insert the plastic piece of each plastic strap #11 into the tubes as shown in diagram A, and position them along the tubes at even intervals over the length X shown in Step 7.

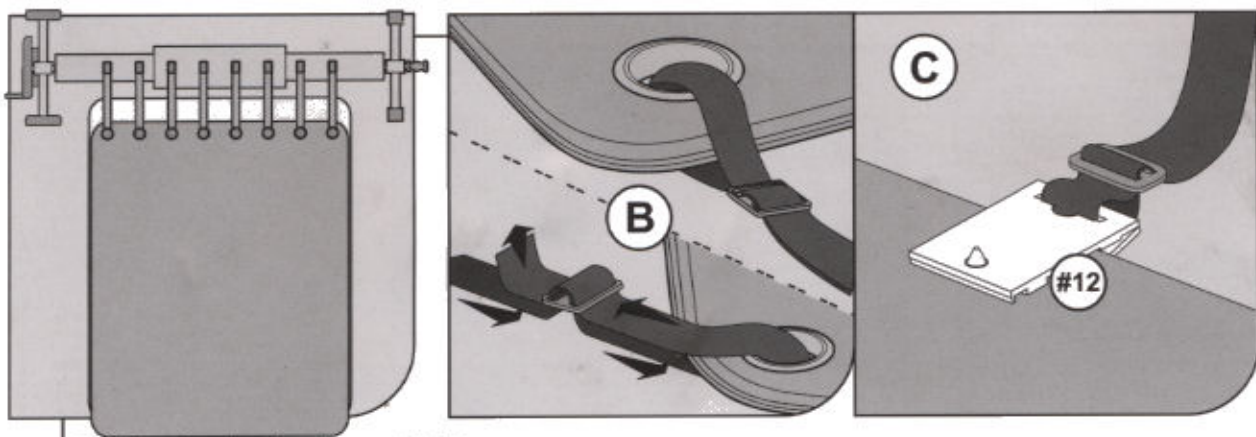

10

**GB For rectangular shaped in ground pools**

- Open cover over the pool and set into position
- If you have grommets on the cover, you can attach the cover strap #11 to the cover by putting the strap through the grommet and securing with the buckle
- #13 provided (Diagram B).
- If there are no grommets, you can attach the cover clip #12, after preassembling with the strap, by snapping onto the cover. (Diagram C). Make sure to position the clips along the cover at the same intervals as the straps will be attached to the tube.
- You can adjust the length of the strap by sliding the buckle.
- Ensure that the length of the straps allows the cover to lay flat on the pool to prevent wind from getting inside under the cover.

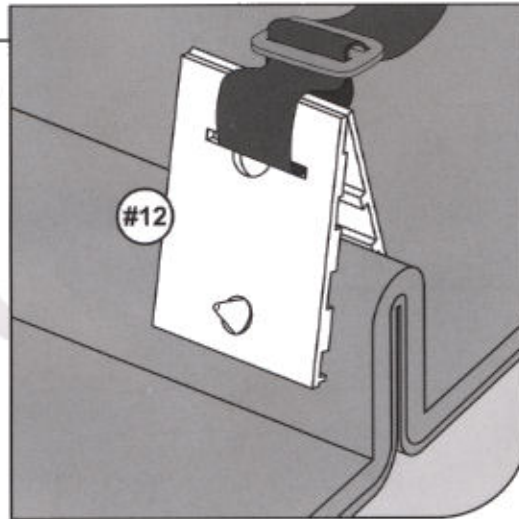
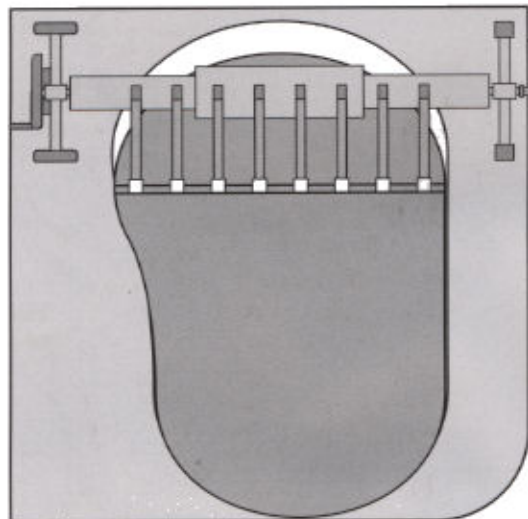

11

**GB For round or oval shaped in ground pools**

- Open cover over the pool and set into position. Fold an edge on the cover with a width sufficient for a cover clip assembly on it. Position the cover clips #12, after preassembling with the strap, along the cover at the same intervals as they will be attached to the tube.
- You can adjust the length of the strap by sliding the buckle.

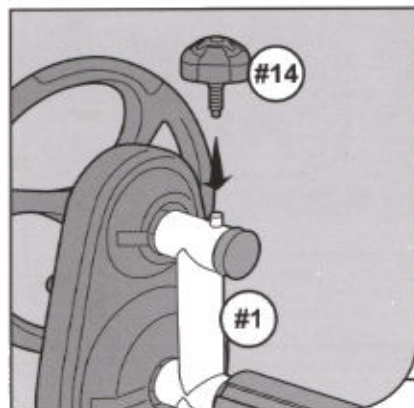

12

**GB Locking the Reel / Crank Wheel in position**

- Fasten the threaded knob #14 to the hole on the top of frame #1.